

# XP26 day/night analogue series - UL range

PTZ camera station,  
hazardous location



## Overview

The Oxalis XP26 is an explosion protected PTZ camera station for use in hazardous areas in onshore, offshore, marine and heavy industrial environments.

The camera housings are designed specifically for the Americas markets or where UL standards on Class and Division have been specified.

The base unit carries dual NPT cable entries with easy access for cable termination during installation as standard, maximising compatibility and ease of use with existing fixed conduit installations.

Our camera stations are designed and manufactured for longevity in harsh environments, require minimal maintenance and are fully certified to UL standards as required by OSHA in both safe and hazardous areas.

See separate datasheet for ATEX/IECEx & other zone certification ranges.

## Features

- Class 1 Division 1 and Zone 1 certified
- Electro-polished 316L stainless steel on all welded assemblies
- Camera station window in toughened glass
- Pole or wall mounting options (see separate datasheets)
- NPT entries as standard
- Various camera module options
- Options also available for IP, analogue, hybrid, IP over Coax and direct fibre out\* - see specific data sheet
- Supply voltage options (24 VAC, 110 or 230 VAC, 50/60Hz)
- Certified temperature from -58°F to +158°F\* (ranging from T4 - T6)
- IP66/67

\*Model dependent

## Certifications

|          |  |
|----------|--|
| UL C1/D1 | Class I, Division 1, Groups B, C, D, T4A(T5 & T6 On Request)<br>Class II, Division 1, Groups E, F, G IP67<br>Class 1 Zone 1 A Ex d IIB + Hydrogen T4 (T5 On Request) |
|----------|--|

## General arrangement drawing (dimensions in inches and mm)

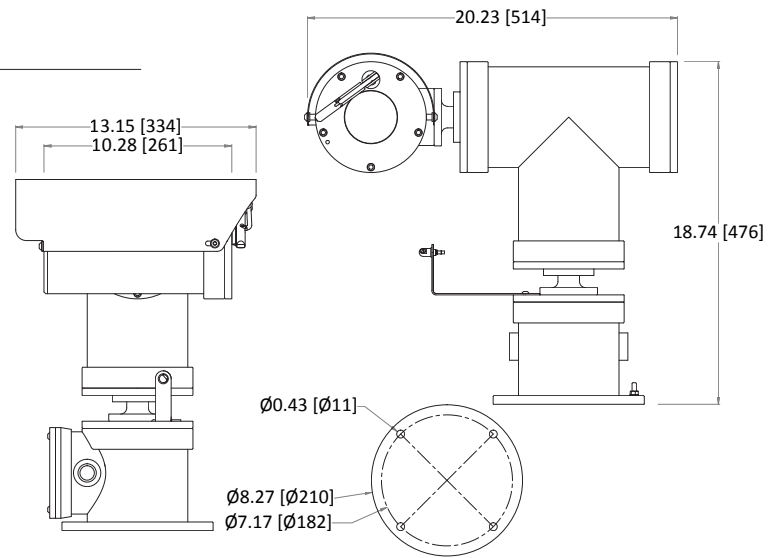

## Specifications

**Certification part number** P&T OXALIS-UL2420-01, Housing options OXALIS-UL2410-04, 2410-05

|                                    |   |
|------------------------------------|---|
| <b>Features</b>                    |   |
| <b>Sun shield</b>                  | Standard stainless steel 316L mirror finish   |
| <b>Integral wiper</b>              | Optional (silicone wiper blades that are resistant and do not perish after long exposure to ozone, UV, ice, snow, heat or cold) |
| <b>Integral demister</b>           | Standard  |
| <b>Washer systems</b>              | Compatible with Oxalis XWP washer tanks (see separate datasheets)   |
| <b>Pan speed (maximum)</b>         | 45° per second  |
| <b>Tilt speed (maximum)</b>        | 24° per second  |
| <b>Pre-set positional accuracy</b> | 64 Presets: positional accuracy±0.1°  |
| <b>Telemetry receiver</b>          | Integral - Pelco D, P standard protocols (others to specification)  |
| <b>Rotation</b>                    | Continuous Pan or 350° Rotation (+/- 175° from straight ahead)  |
| <b>Analogue direct fibre out</b>   | Optional singlemode 9/125µm or multimode 50/125µm video and data fibre optic transmission, mounted inside the camera station    |
| <b>Integral IP encoder</b>         | Not applicable  |
| <b>IP direct fibre out</b>         | Not applicable  |
| <b>Electrical</b>                  |   |
| <b>Supply voltage options</b>      | 24 VAC, 110 or 230 VAC, 50/60Hz   |
| <b>Power consumption</b>           | 85W Maximum (143W with low temperature operation)   |
| <b>Electrical connections</b>      | Terminal block for power, data and video specific to camera configuration   |
| <b>Cable entry</b>                 | 2 x 3/4" NPT located in base  |
| <b>Mechanical</b>                  |   |
| <b>Body material</b>               | Electro-polished 316L stainless steel on all welded assemblies  |
| <b>Fixings material</b>            | A4 stainless steel  |
| <b>Camera station window</b>       | Toughened glass   |
| <b>Mounting options</b>            | Pole or wall (see separate datasheets)  |
| <b>Operating temperature</b>       | From -58°F to +158°F (model dependent)  |
| <b>Weight (lb)</b>                 | Up to 101lb depending on configuration  |
| <b>Ingress protection rating</b>   | IP66/67   |
| <b>Approvals</b>                   |   |
| <b>Type approval</b>               | DNV 2.4 2006 ABCD (copper transmission only)  |
| <b>Camera options</b>              |   |
| <b>1/4" CCD 36x zoom camera</b>    |   |
| <b>Image sensor</b>                | 1/4" EXview HAD CCD (progressive scan)  |
| <b>Resolution</b>                  | High resolution mode on: 550 TV lines (default)   |
| <b>Lens</b>                        | 36x zoom 3.4-122.4 mm F1.6 to F4.5, horizontal angle of view 57.8° - 1.7°, 12X digital zoom, auto focus, auto iris              |
| <b>Min. illumination</b>           | 1/60 s, 1/50 s mode: 1.4 Lux, 1/4 s, 1/3 s mode: 0.1 Lux, 1/4 s, 1/3 s mode & ICR On: 0.01 Lux                                  |
| <b>S/N ratio</b>                   | >50dB   |
| <b>Features</b>                    | ATW, day & night auto/colour / BW (IR-Cut filter removable), camera title ON/OFF  |

# Ordering requirements

The following code is designed to help in selection of the correct unit. Build up the reference number by inserting the code for each component into the appropriate box

|      |  |  |  |  |  |  |  |  |  |  |  |  |  |  |
|------|--|--|--|--|--|--|--|--|--|--|--|--|--|--|
| XP26 |  |  |  |  |  |  |  |  |  |  |  |  |  |  |
|------|--|--|--|--|--|--|--|--|--|--|--|--|--|--|

| Housing type          | Code |
|-----------------------|------|
| Visual camera housing | V    |

| Wiper options   | Code |
|---|------|
| Integral wiper with switched 24VAC for external washer pump | E    |
| No wiper  | N    |

| Video type     | Code |
|----------------|------|
| Analogue video | A    |

| Day/night module         | Code |
|--------------------------|------|
| 1/4" CCD 36x zoom camera | 4    |
| Customer specific camera | C    |

| Thermal core module | Code |
|---------------------|------|
| No thermal core     | N    |

| Thermal core lens       | Code |
|-------------------------|------|
| No thermal imaging lens | N    |

| Video system | Code |
|--------------|------|
| PAL          | P    |
| NTSC         | N    |

| Supply voltage                 | Code |
|--------------------------------|------|
| 24 VAC ±10% 50/60 Hz           | 1    |
| 110 VAC ±10% 50/60 Hz          | 2    |
| 230 VAC ±10% 50/60 Hz          | 3    |
| Special - price on application | S    |

| Transmission type                     | Code |
|---------------------------------------|------|
| Standard electrical                   | 0    |
| Simplex singlemode 9/125µm video/data | 1    |
| Simplex multimode 50/125µm video/data | 2    |
| Customer specific transmission device | C    |

| Temperature type    | Code |
|---------------------|------|
| T4A -4°F to +158°F  | E    |
| T4A -58°F to +158°F | F    |
| T6 -4°F to +122°F*  | G    |
| T6 -58°F to +122°F* | H    |

\*Subject to restrictions

| Certification    | Code |
|------------------|------|
| UL Class I Div I | L    |

| Protocol requirements               | Code |
|-------------------------------------|------|
| Pelco D protocol, baud rate 2400bps | D    |
| Pelco P protocol, baud rate 4800bps | P    |
| Vicon protocol, baud rate 4800bps   | V    |
| HERNISTM protocol                   | H    |
| Coe protocol                        | C    |
| Special - price on application      | S    |

| Camera rotation                     | Code |
|-------------------------------------|------|
| Continuous rotation                 | 1    |
| Pan rotation restricted to +/- 175° | 2    |