

XF26 day/night analogue series - UL range

Fixed camera station,
hazardous location



Overview

The Oxalis XF26 is an explosion protected fixed camera housing for use in hazardous areas in onshore, offshore, marine and heavy industrial environments.

The camera housings are designed specifically for the Americas markets or where UL standards on Class and Division have been specified. As a result they utilise NPT entries as standard to maximise compatibility with existing fixed conduit installations.

Our camera stations are designed and manufactured for longevity in harsh environments, require minimal maintenance and are fully certified to UL standards as required by OSHA in both safe and hazardous areas.

See separate datasheet for ATEX/IECEX & other zone certification ranges.

Features

- Class 1 Division 1 and Zone 1 certified
- Electro-polished 316L stainless steel on all welded assemblies
- Camera station window in toughened glass
- Pole or wall mounting options (see separate datasheets)
- NPT entries as standard
- Various camera module options
- Options also available for IP, analogue, hybrid, IP over Coax and direct fibre out* - see specific datasheet
- Supply voltage options 24 VAC
- Certified temperature from -58°F to +158°F* (ranging from T4 - T6)
- IP66/67

*Model dependent



Certifications

UL C1/D1	Class I, Division 1, Groups B, C, D, T4A(T5 & T6 On Request) Class II, Division 1, Groups E, F, G IP67 Class 1 Zone 1 A Ex d IIB + Hydrogen T4 (T5 On Request)
----------	--

General arrangement drawing (dimensions in inches and mm)

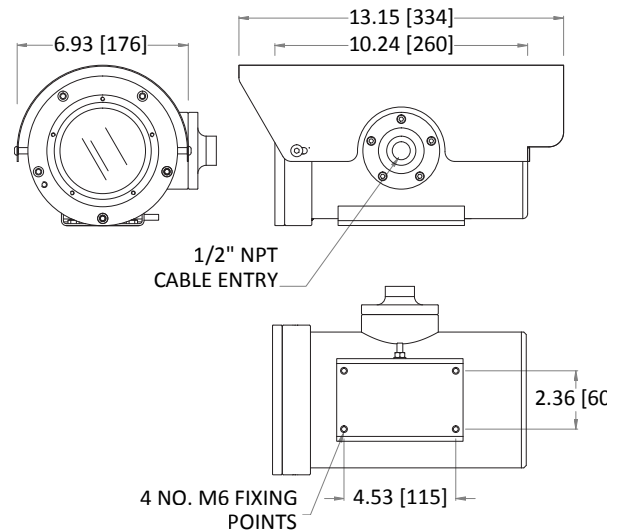

Specifications

Certification part number	Housing options OXALIS-UL2410-04, 2410-05
Features	
Sun shield	Standard stainless steel 316L mirror finish
Integral wiper	Optional (silicone wiper blades that are resistant and do not perish after long exposure to ozone, UV, ice, snow, heat or cold)
Integral demister	Standard
Washer systems	Compatible with Oxalis XW or XWP washer tanks (see separate datasheets)
Telemetry receiver	Integral - Pelco D, P standard protocols (others to specification)
Ingress protection rating	IP66/67, IP68 (1.5m for 24 hours)
Type approval	DNV 2.4 2006 ABCD (copper transmission only)
Electrical	
Supply voltage options	24 VAC
Power consumption	18W maximum (45W with low temperature operation)
Electrical connections	Terminal block for power, data and video specific to camera configuration
Cable entry	1 x 1/2" NPT located on housing side
Mechanical	
Body material	Electro-polished 316L stainless steel on all welded assemblies
Fixings material	A4 stainless steel
Camera station window	Toughened glass
Mounting options	Pole or wall (see separate datasheets)
Operating temperature	From -58°F to +158°F (model dependent)
Weight (lb)	Up to 18lb depending on configuration
Camera options	
1/4" CCD 36x zoom camera	
Image sensor	1/4" EXview HAD CCD (progressive scan)
Resolution	High resolution mode on: 550 TV lines (default)
Lens	36x zoom 3.4-122.4 mm F1.6 to F4.5, horizontal angle of view 57.8°- 1.7°, 12X digital zoom, auto focus, auto iris
Min. illumination	1/60 s, 1/50 s mode: 1.4 Lux, 1/4 s, 1/3 s mode: 0.1 Lux, 1/4 s, 1/3 s mode & ICR On: 0.01 Lux
S/N ratio	>50dB
Features	ATW, day & night auto/colour / BW (IR-cut filter removable), camera title ON/OFF

Ordering requirements

The following code is designed to help in selection of the correct unit. Build up the reference number by inserting the code for each component into the appropriate box

